

Das Verstellen der Roto Beschlagteile darf nur von autorisiertem Fachpersonal ausgeführt werden.

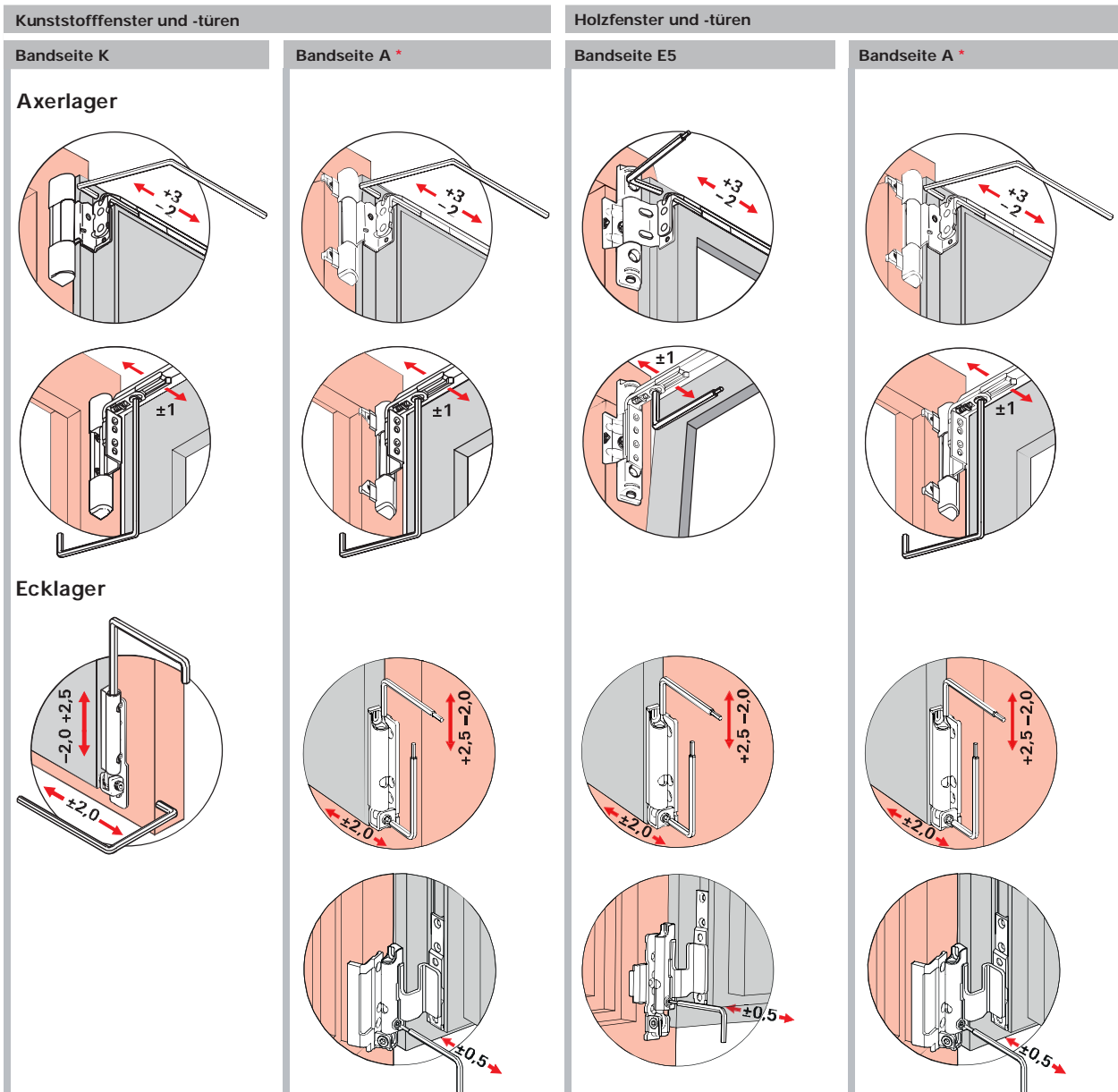

\* Beim Einsatz von Abdeckkappen (Axerlager/Ecklager) und Eckbandsicherung ändern sich die angegebenen Verstellmaße.

Verstellwerkzeuge		
Bild	Bezeichnung	Material-Nr.
	Sechskant-Schraubendreher 4 mm	208 609
	Sechskant-Schraubendreher 2,5/4 mm	230 764

**Roto Frank AG**  
Fenster- und Türtechnologie

Wilhelm-Frank-Platz 1  
70771 Leinfeldern-Echterdingen  
Telefon +49 711 7598-0 • Telefax +49 711 7598-253  
info@roto-frank.com • www.roto-frank.com



**Schließzapfen E**

Verstellwerkzeug	Verstellweg in °	Anpressdruckverstellung in mm
	 <p>Grundstellung 0°</p>	-

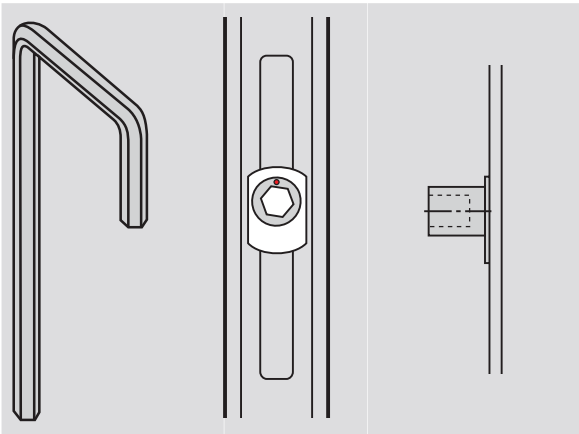

**Schließzapfen P**

Verstellwerkzeug	Verstellweg in °	Anpressdruckverstellung in mm
	 <p>Grundstellung 0°</p>	-

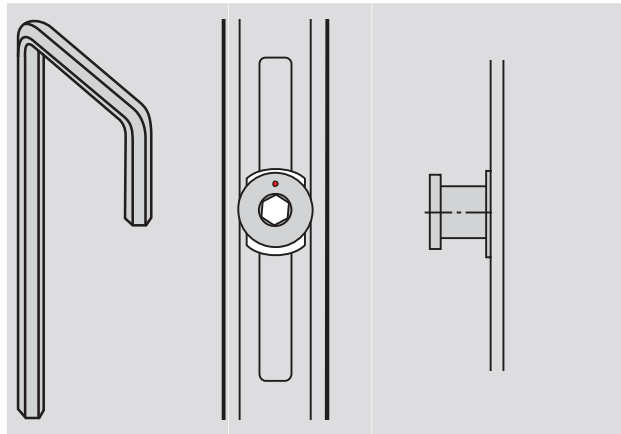
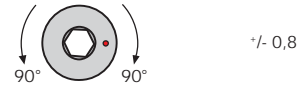

**Schließzapfen V**

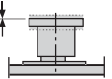
Verstellwerkzeug	Verstellweg in °	Anpressdruckverstellung in mm	Höhenverstellung in mm
			

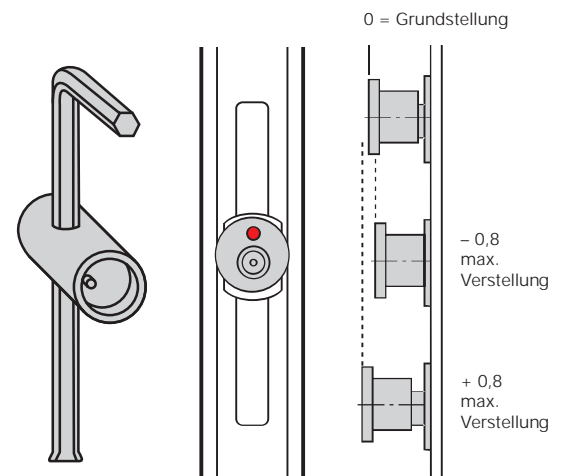

 <p>Grundstellung 0°</p>	-	-
 <p>90°</p>	$\pm 0,8$	$\pm 0,2$
 <p>180°</p>	-	$\pm 0,4$
 <p>270°</p>	$\pm 0,8$	$\pm 0,6$
 <p>360°</p>	-	$\pm 0,8$

